



IMPROVING CARE

MATERIAL SOLUTIONS FOR PREFILLED FLUSH SYRINGES

Healthcare professionals trust your devices to deliver simplified, reliable and critical care. To meet the growing demands for patient safety and improved patient comfort, prefilled flush syringes play an increasingly critical role in simplifying care and administering important medications when it matters most.

A prefilled flush syringe may appear to be a straightforward drug delivery device, but product development and innovation is far from simple. To succeed, your products and components must meet stringent regulatory standards and application-specific demands that contribute to improved patient care.

Our in-depth industry knowledge, technical capabilities and expansive material solutions help you to address those challenges. We'll work with you to optimize part design, navigate regulatory processes, meet performance specifications, shorten the product development cycle, and more.



**MORE THAN
MATERIALS**

DELIVERING SAFETY & PERFORMANCE

Healthcare professionals rely on innovative and dependable devices to deliver essential patient care. When designing prefilled flush syringes, you need the same innovative approach and reliable performance to help caregivers succeed. PolyOne Distribution's comprehensive approach to materials solutions and product development can help meet those challenges.

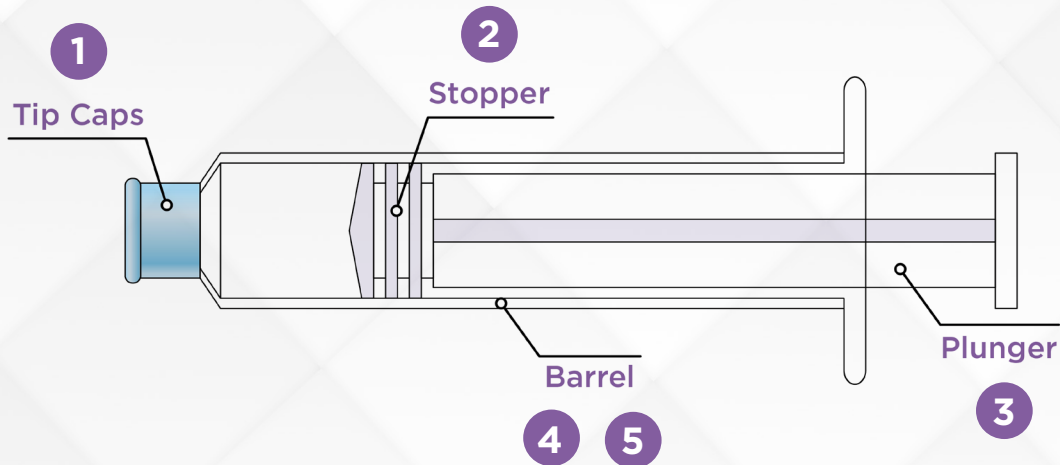

1. PROTECTION

Biocompatibility, Reliable Sealing, Durability

SOLUTION: Medical Polypropylene

2. SAMPLE CONTROL

Biocompatibility, Chemical Resistance, Low Extractables & Leachables

SOLUTIONS: Butyl Rubber, Thermoplastic Vulcanizate (TPV)

3. PERFORMANCE

Biocompatibility, Rigidity, High Heat Resistance

SOLUTION: Medical Polypropylene

4. RELIABILITY & AESTHETICS

Biocompatibility, Rigidity, High Clarity, Low Extractables & Leachables

SOLUTION: Medical Clarified Polypropylene

5. EASE OF DISPENSING

Stable, Consistent Pushing Force

SOLUTION: Medical Silicone Fluid

1.866.POLYONE
www.polyonedistribution.com

PolyOne[™]

Copyright © 2019, PolyOne Corporation. PolyOne makes no representations, guarantees, or warranties of any kind with respect to the information contained in this document about its accuracy, suitability for particular applications, or the results obtained or obtainable using the information. Some of the information arises from laboratory work with small-scale equipment which may not provide a reliable indication of performance or properties obtained or obtainable on larger-scale equipment. Values reported as "typical" or stated without a range do not state minimum or maximum properties; consult your sales representative for property ranges and min/max specifications. Processing conditions can cause material properties to shift from the values stated in the information. PolyOne makes no warranties or guarantees respecting suitability of either PolyOne's products or the information for your process or end-use application. You have the responsibility to conduct full-scale end-product performance testing to determine suitability in your application, and you assume all risk and liability arising from your use of the information and/or use or handling of any product. POLYONE MAKES NO WARRANTIES, EXPRESS OR IMPLIED, INCLUDING, BUT NOT LIMITED TO, IMPLIED WARRANTIES OF MERCHANTABILITY AND FITNESS FOR A PARTICULAR PURPOSE, either with respect to the information or products reflected by the information. This literature shall NOT operate as permission, recommendation, or inducement to practice any patented invention without permission of the patent owner.